

Shyamjyot Industries

:: Group of ::

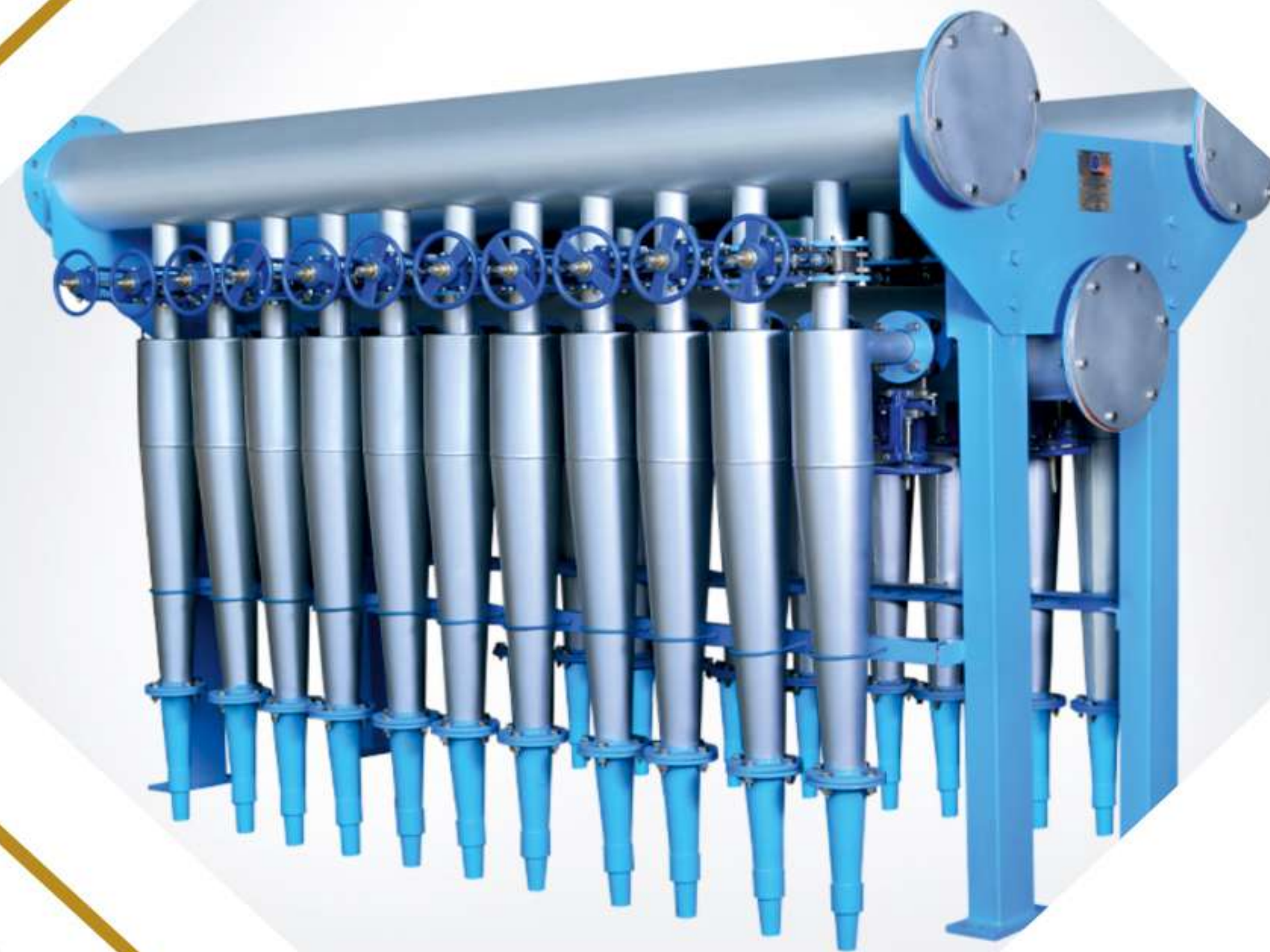

**DAS CONSULTANT
& ENGINEERS**



COMPANY PROFILE



Mr. SHYAMAL DAS
(Director)

Established in the Year 1988, DAS CONSULTANT AND ENGINEERS & SHYAMJYOT INDUSTRIES are started in year 2013 and is a leader in process efficiency and energy conservation for Process Industry, with over seven decades of experience building steam engineering and control instrumentation solutions. Our unique complementary expertise enables us to engineer customised systems that improve manufacturing processes, conserve energy and are environmentally sustainable. We offer our customers a comprehensive range of services, products and solutions for utilities and process control. We are present in over 60 locations in India, with 7 manufacturing facilities. Our knowledge, innovative solutions, reliable products and global presence make us a trusted partner.

Connect to Your Success with Us

DAS CONSULTANT AND ENGINEERS & SHYAMJYOT INDUSTRIES are your most trustworthy partner and your first choice for Paper machinery plant parts.

DAS CONSULTANT AND ENGINEERS & SHYAMJYOT INDUSTRIES are dedicated to provide the world-class products parts. Our value proposition is built upon on the core principle of "Connect to Your Success". This is a common goal we share with our customers. This guiding principle drives us to develop integrated service innovations, which enables us to win in every promising market, and to connect every success in the networking business.



TURNKEY PROJECTS

We are providing turnkey projects along with :

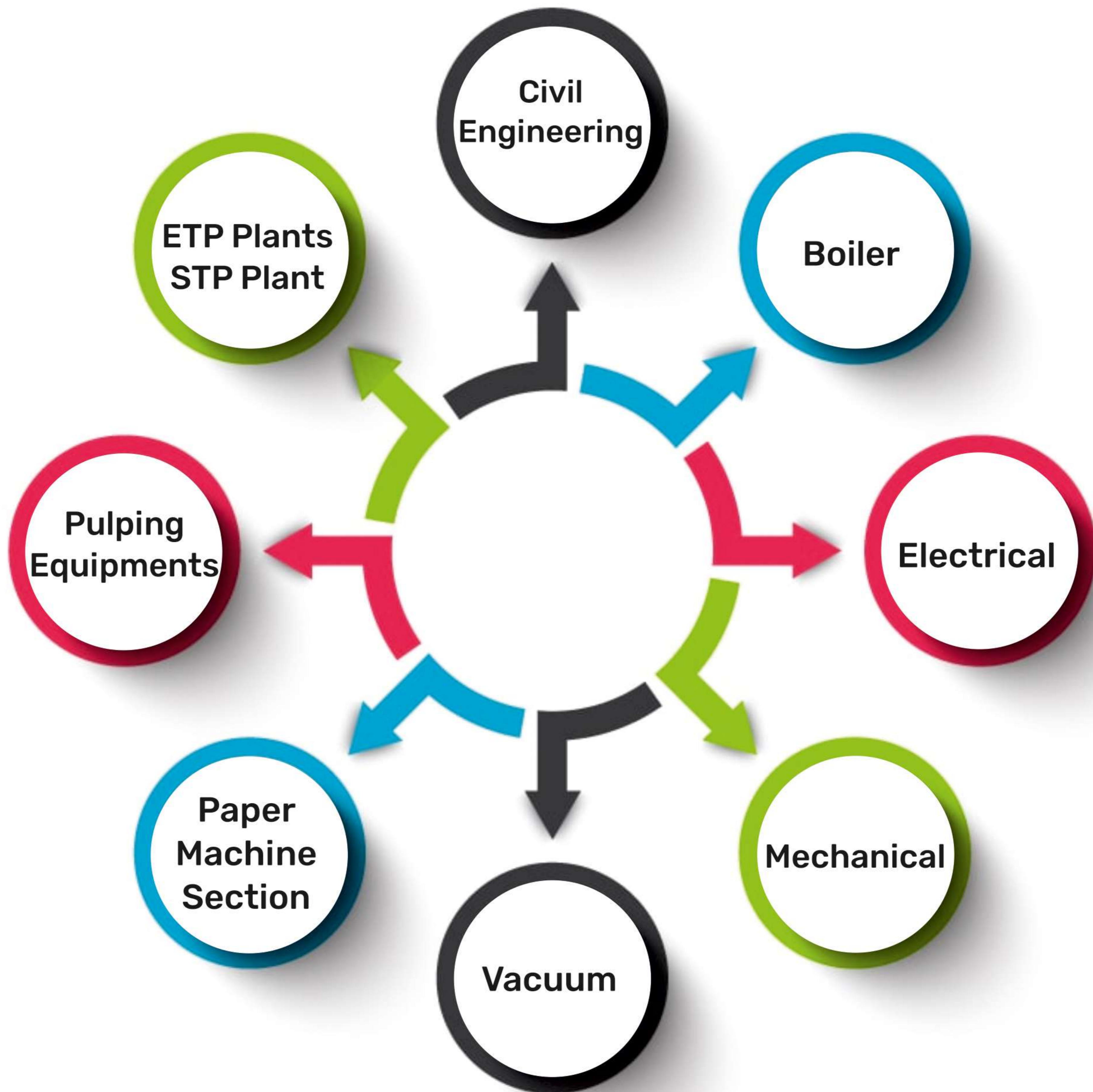

Excellent designing software with skilled designer to improve the machine quality and work efficiency.

FULL PLANT SUPPLIER ALONG WITH CONSULTANCY

HARSIDDH PAPER MILL - SIDHPUR	50 TPD
SIDDHESHWARI PAPER MILL - PALANPUR	50 TPD
NILKANTH CRAFT PAPER MILL - MEHSANA	120 TPD
BALARAM PAPER MILL - NANDASAN	120 TPD
MAHADEV CRAFT PAPER MILL - NANDASAN	200 TPD
MADHUSUDAN PAPER MILL - MORBI	150 TPD
RAMEST PAPER MILL - MORBI	100 TPD
KAILASH PAPER MILL - MORBI	100 TPD
SHREEJI KELA PAPER MILL - SIDHPUR	150 TPD

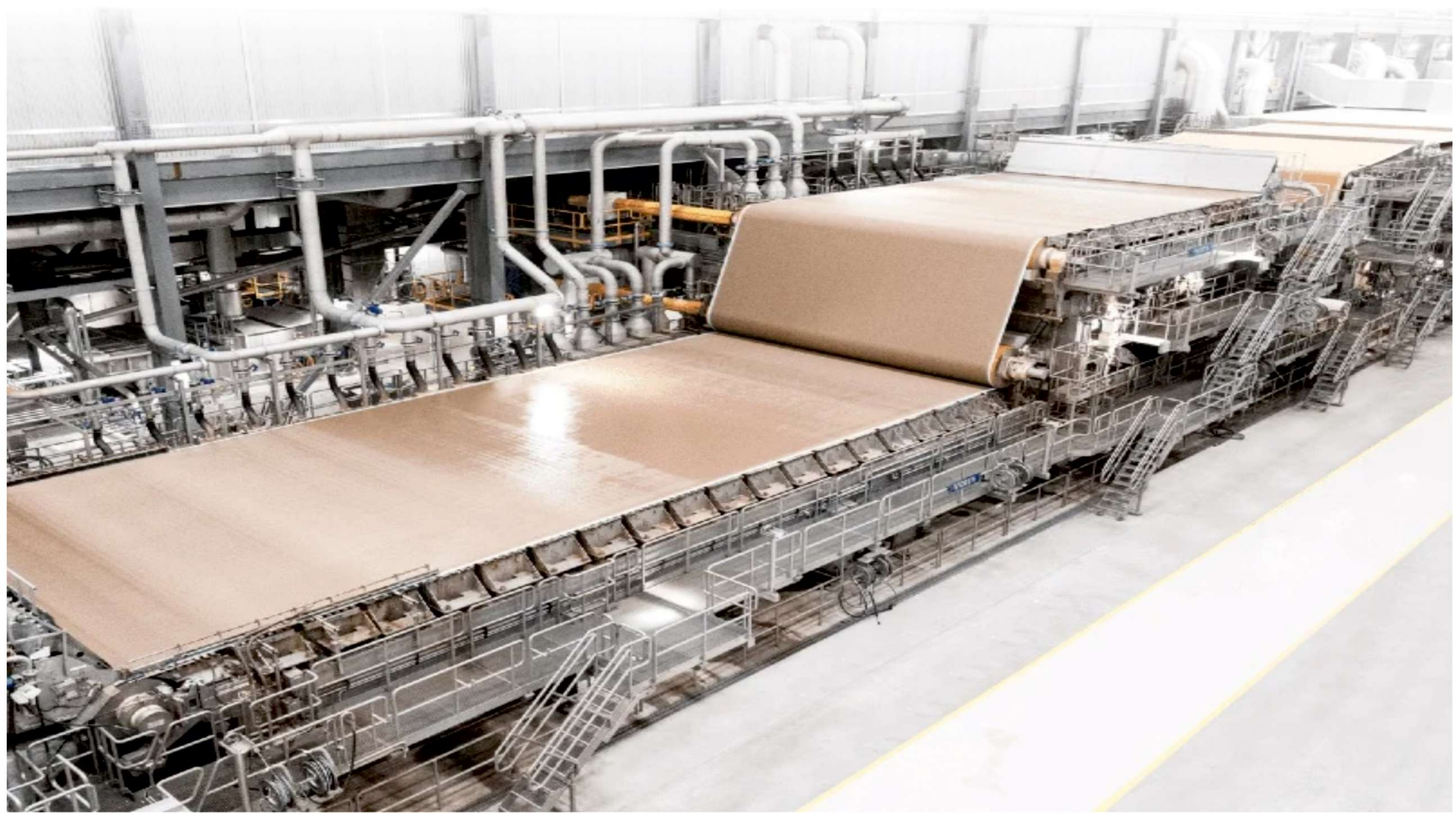

OUR PRODUCTS

**HI CONSISTENCY
PULPER & SYSTEM**



CENTRICLEANER

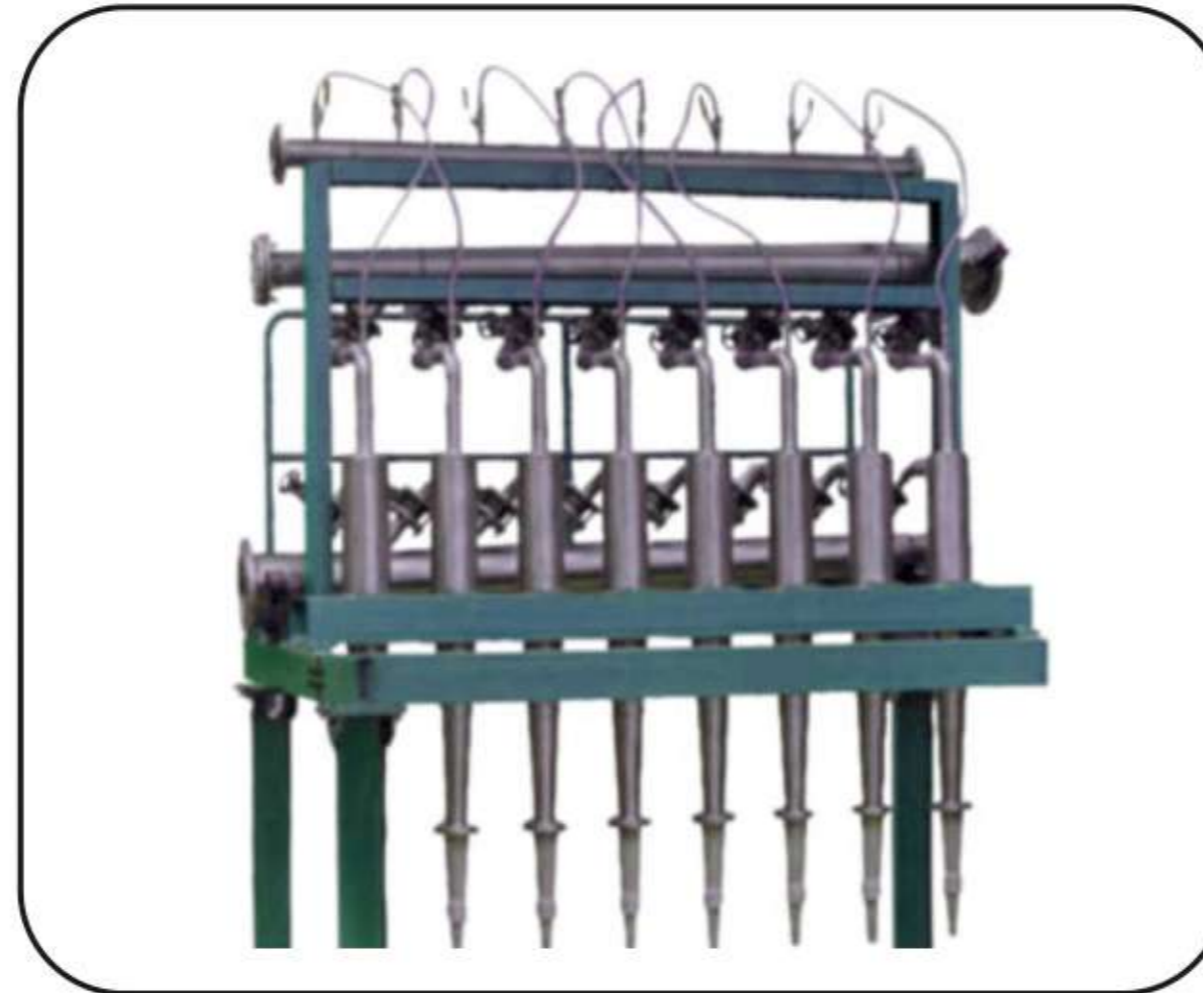

SIZE PRESS

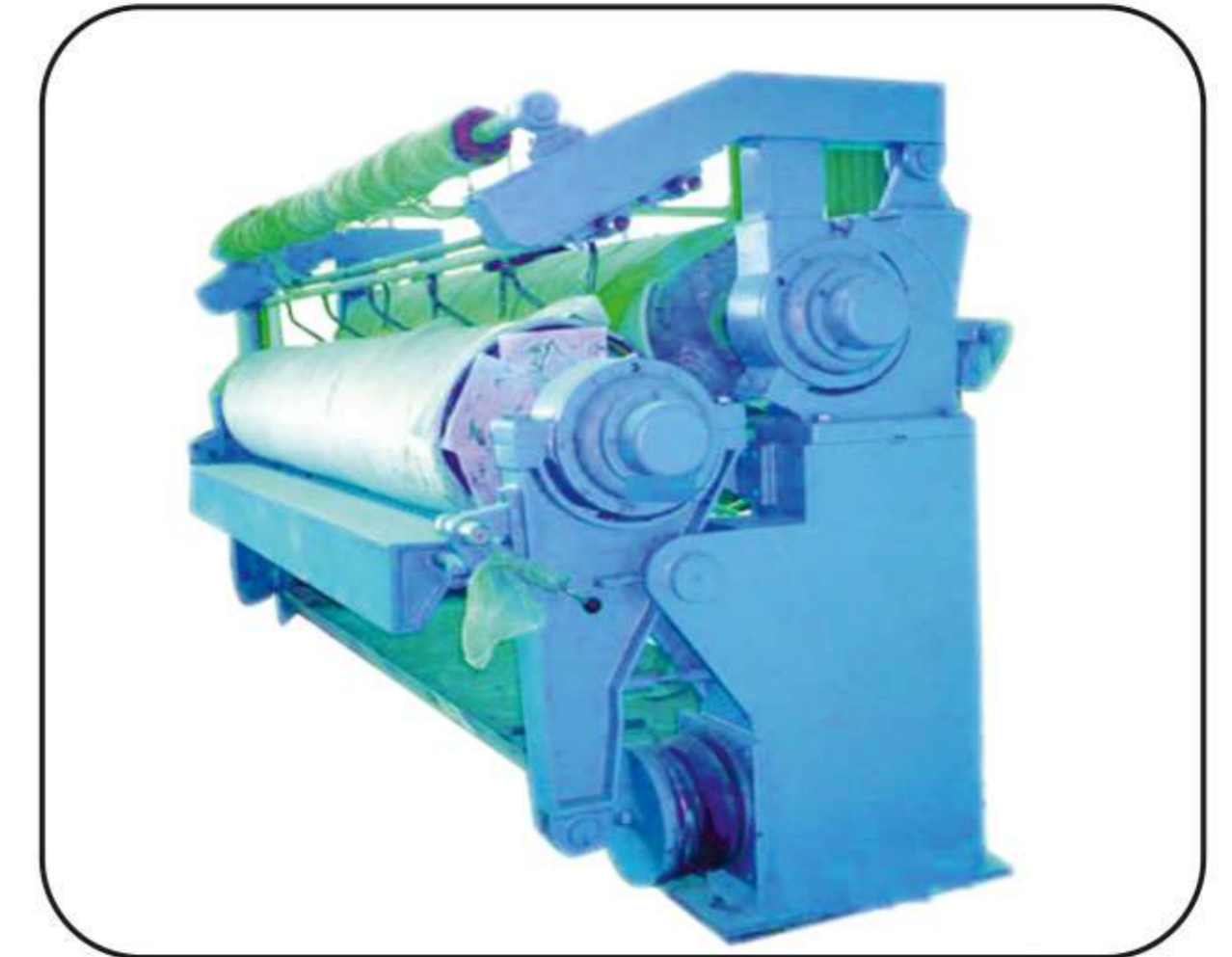

DILUTION PULPER

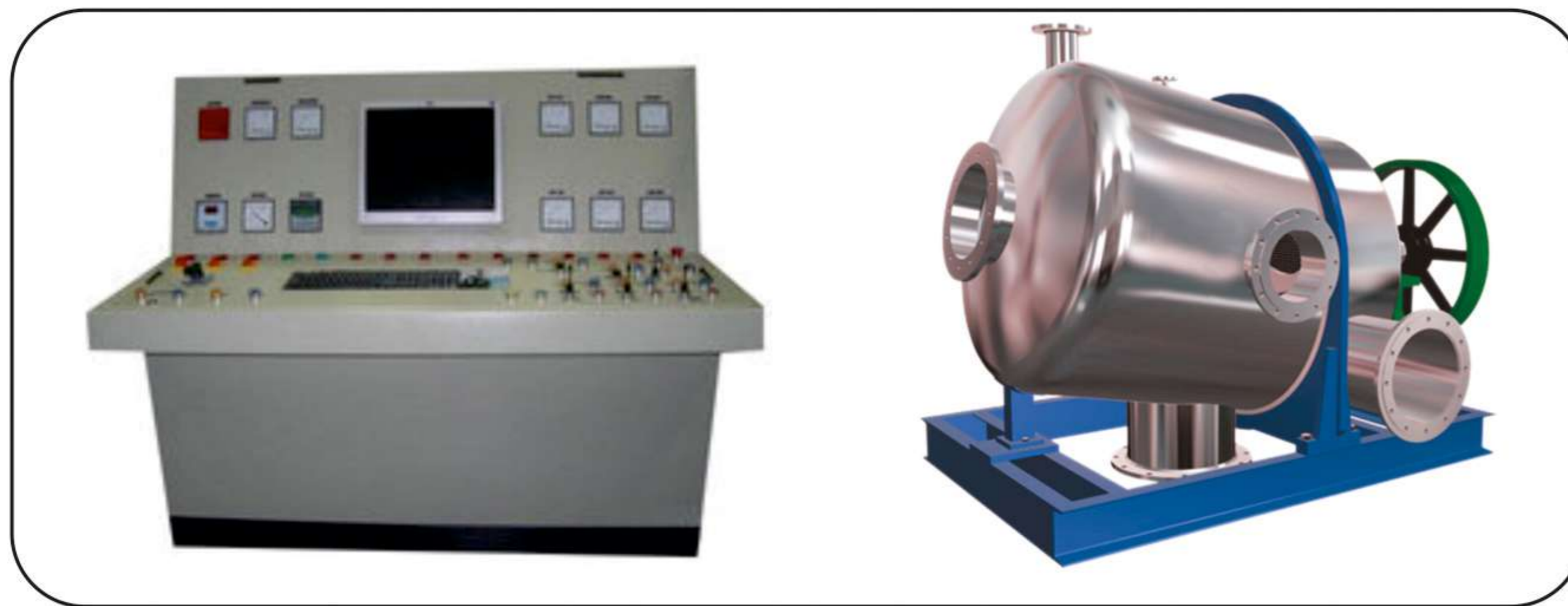

**HIGH DENSITY
CLEANER (MOTORISED)**



FIBER SAVER

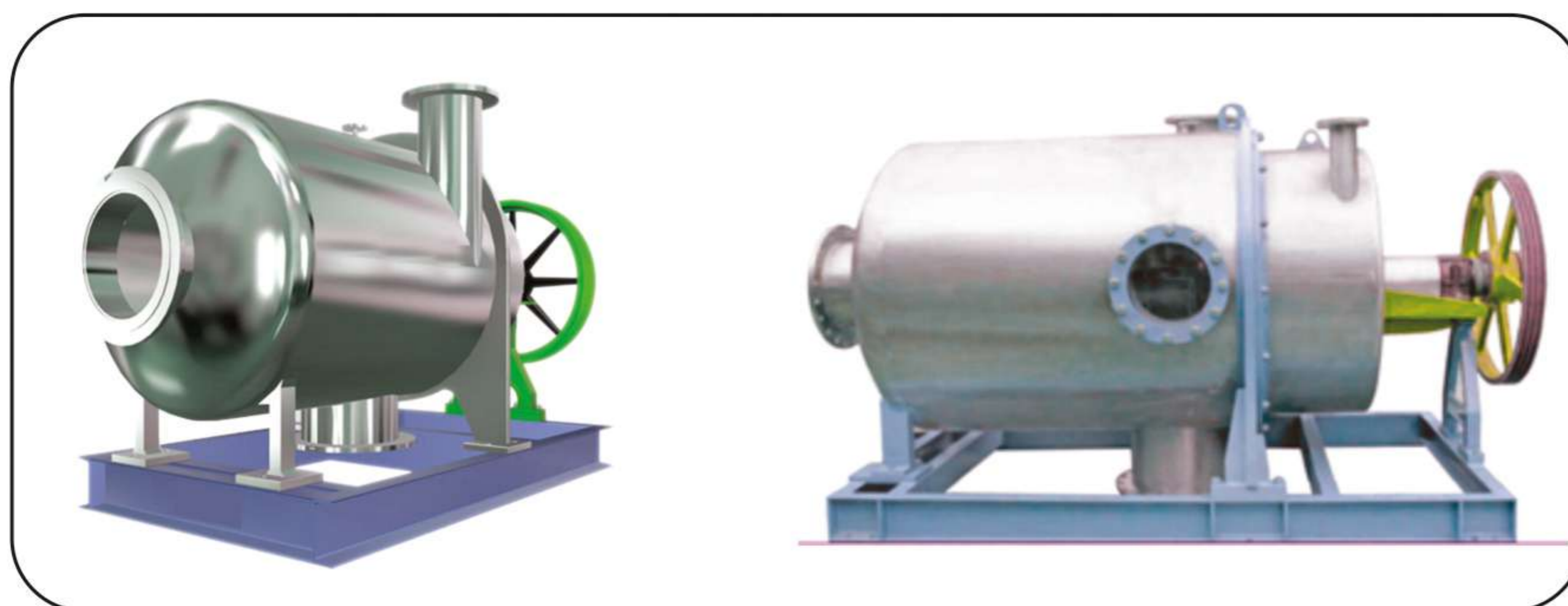

REWINDER

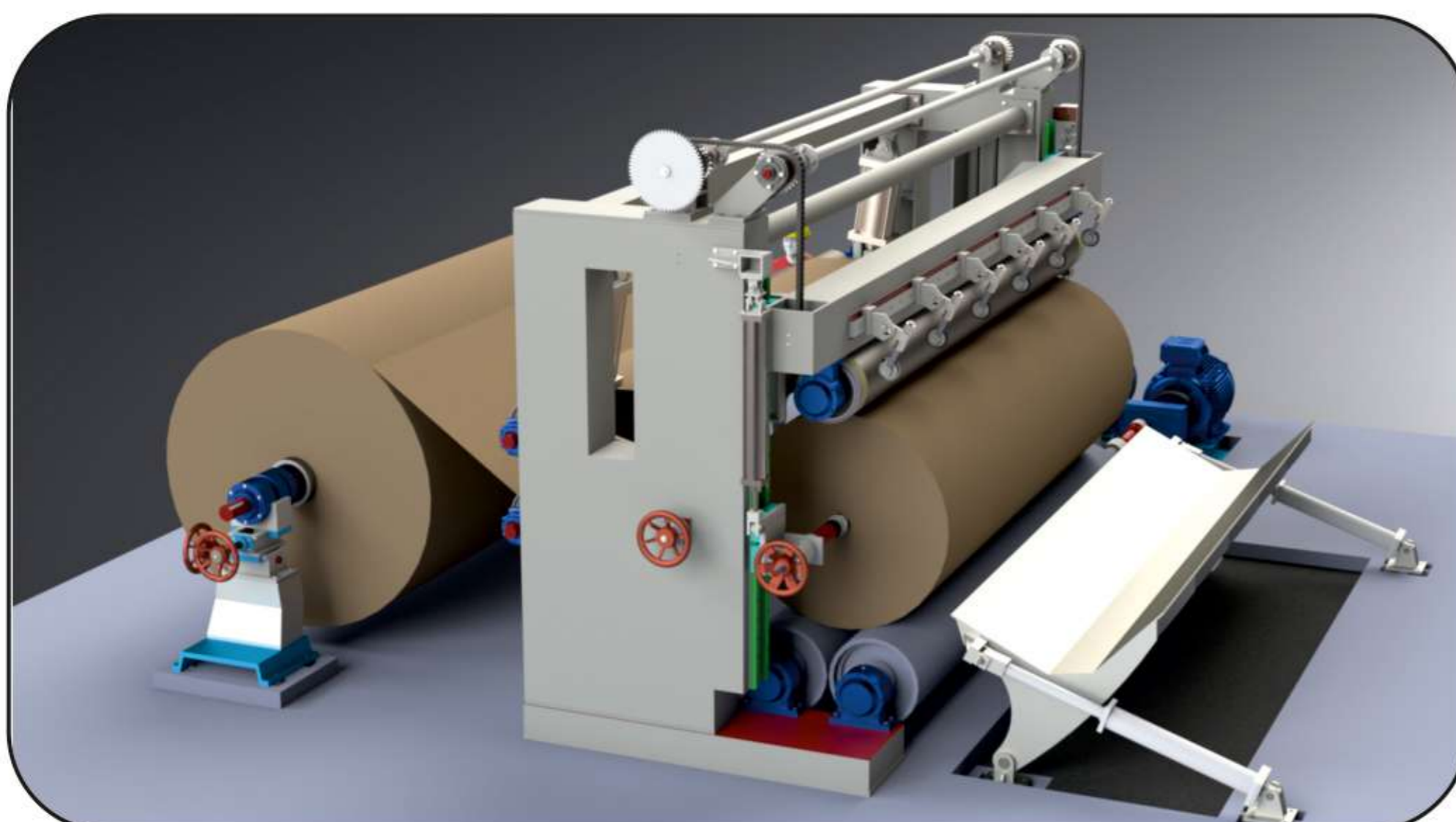

TROMMEL SCREEN

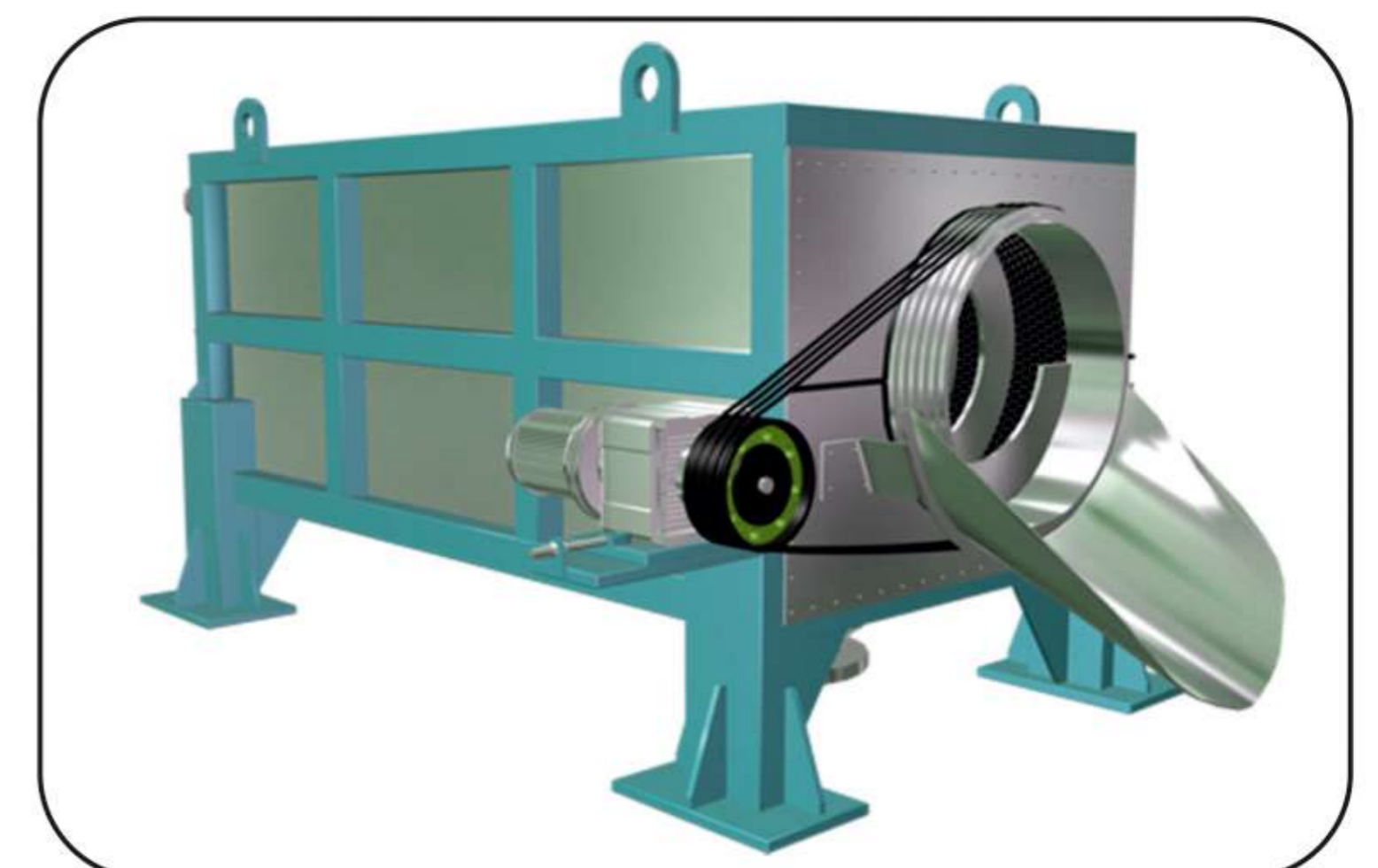

TWIN WIRE WITH MF MACHINE

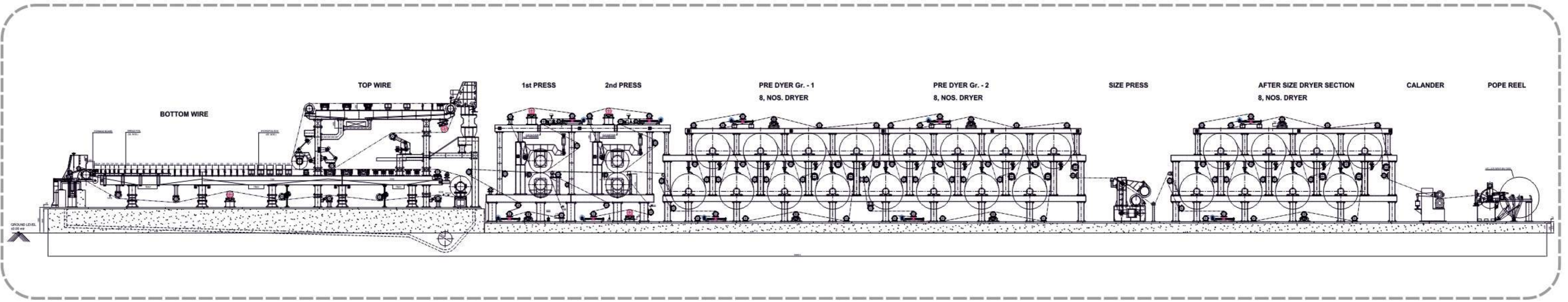

MOULD MACHINE

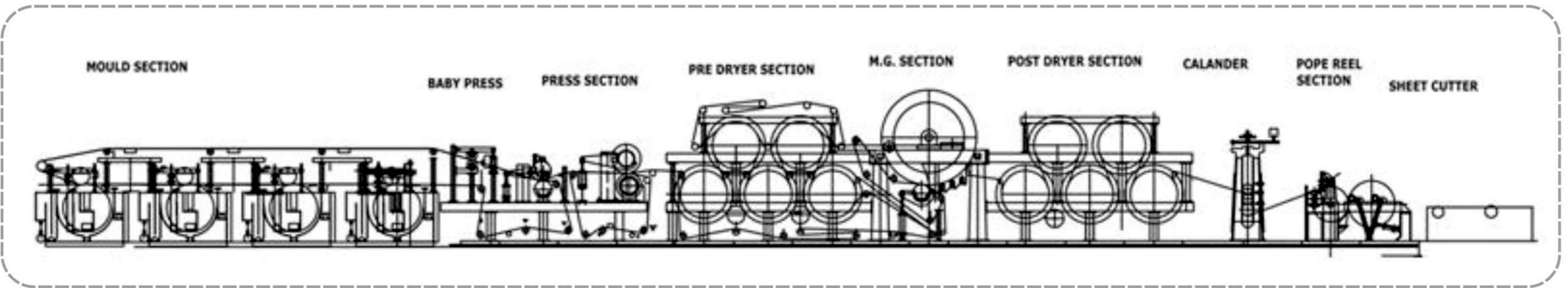

TWIN WIRE WITH MG CYLINDER MACHINE

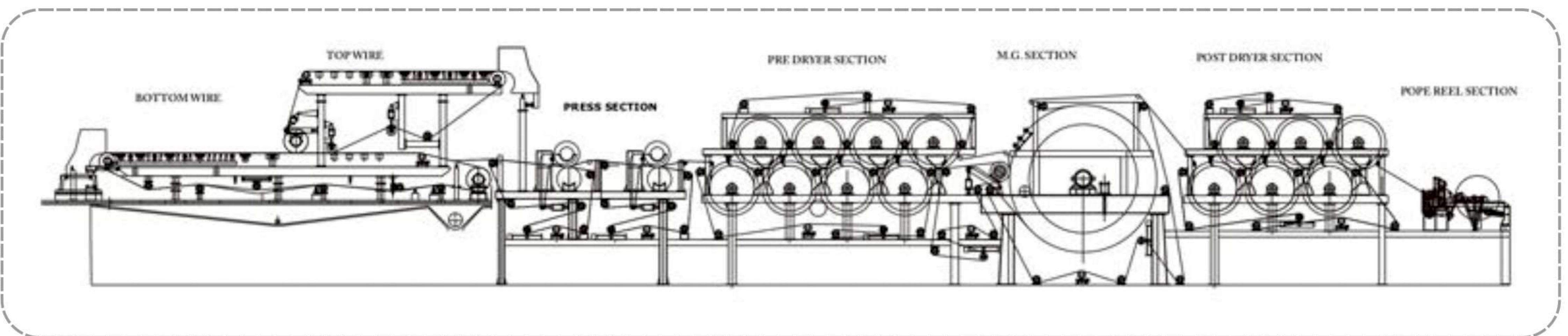

FOURDRINIER WIRE PART MACHINE

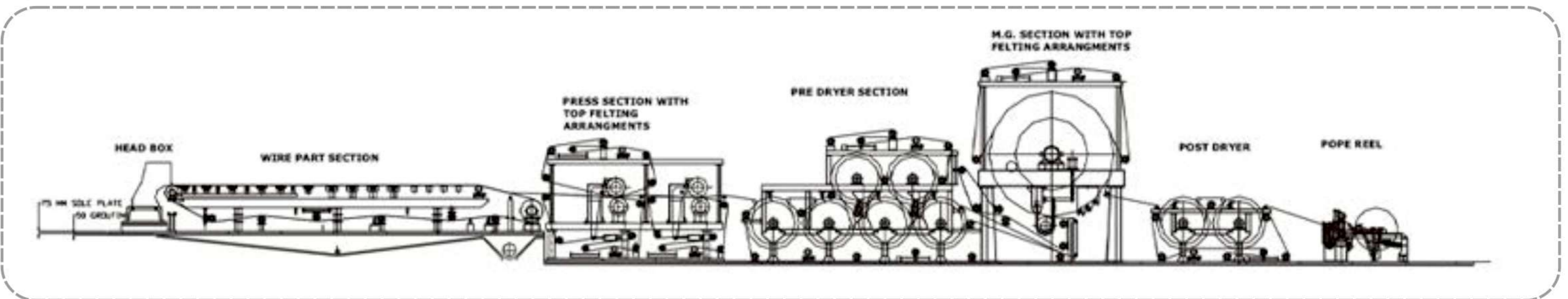

YANKEE MACHINE

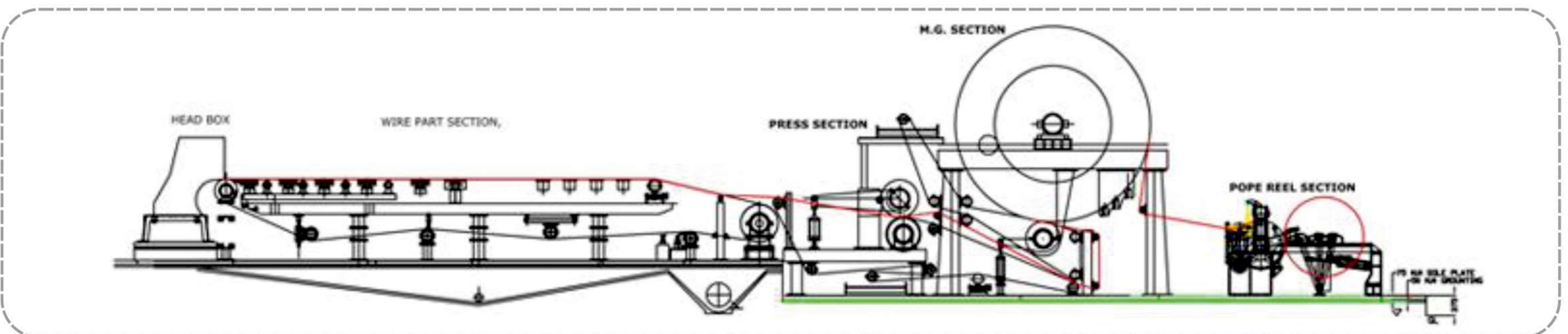

FOUR WIRE PART MACHINE

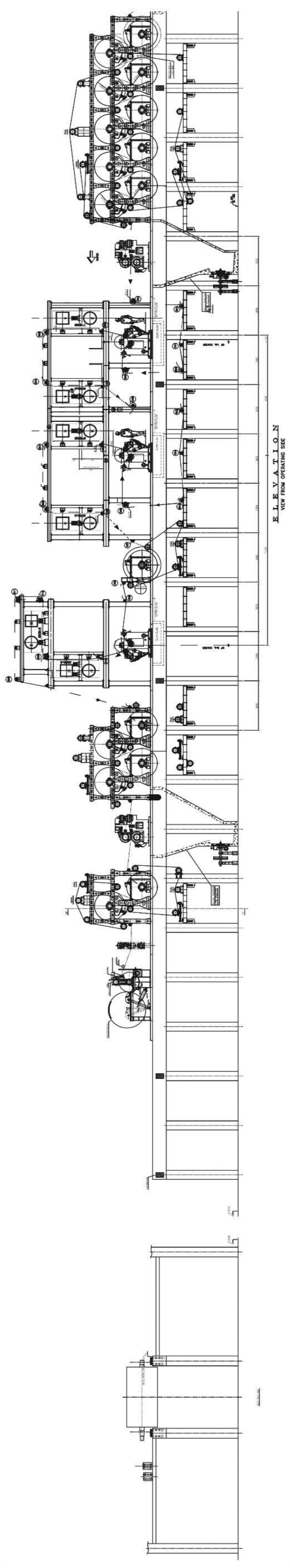
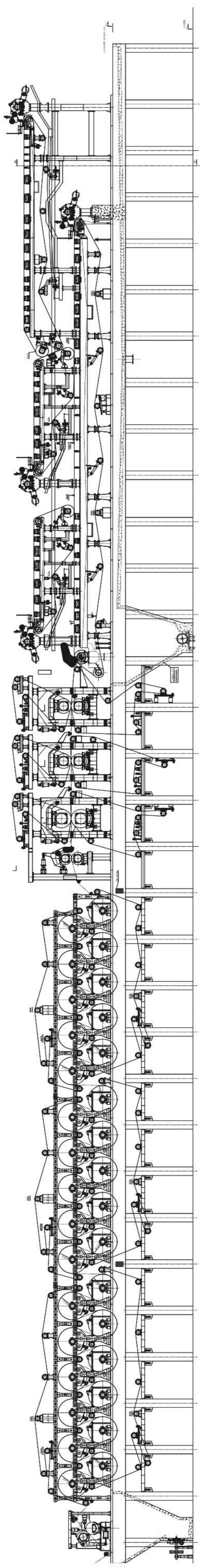

DUPLEX BOARD MACHINE

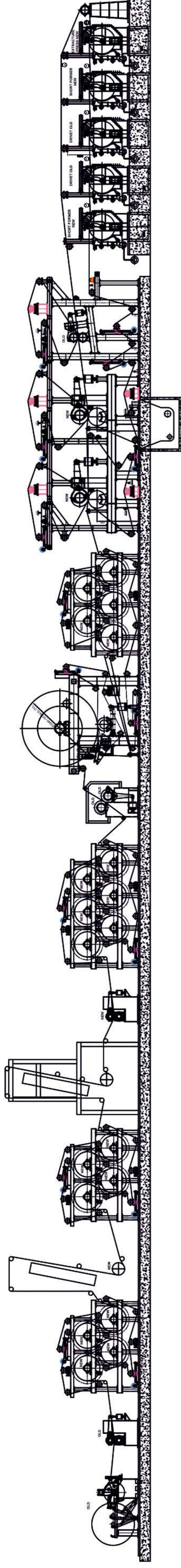

PAPER MACHINE LAYOUT

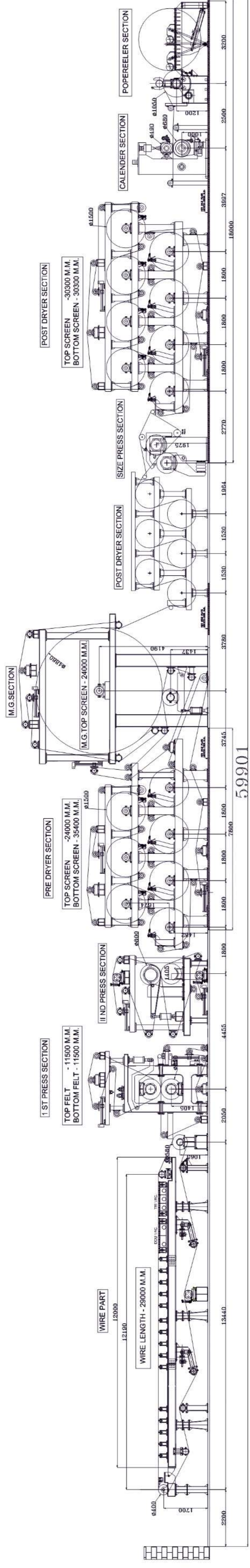

ABSORMENT KRAFT PAPER MACHINE

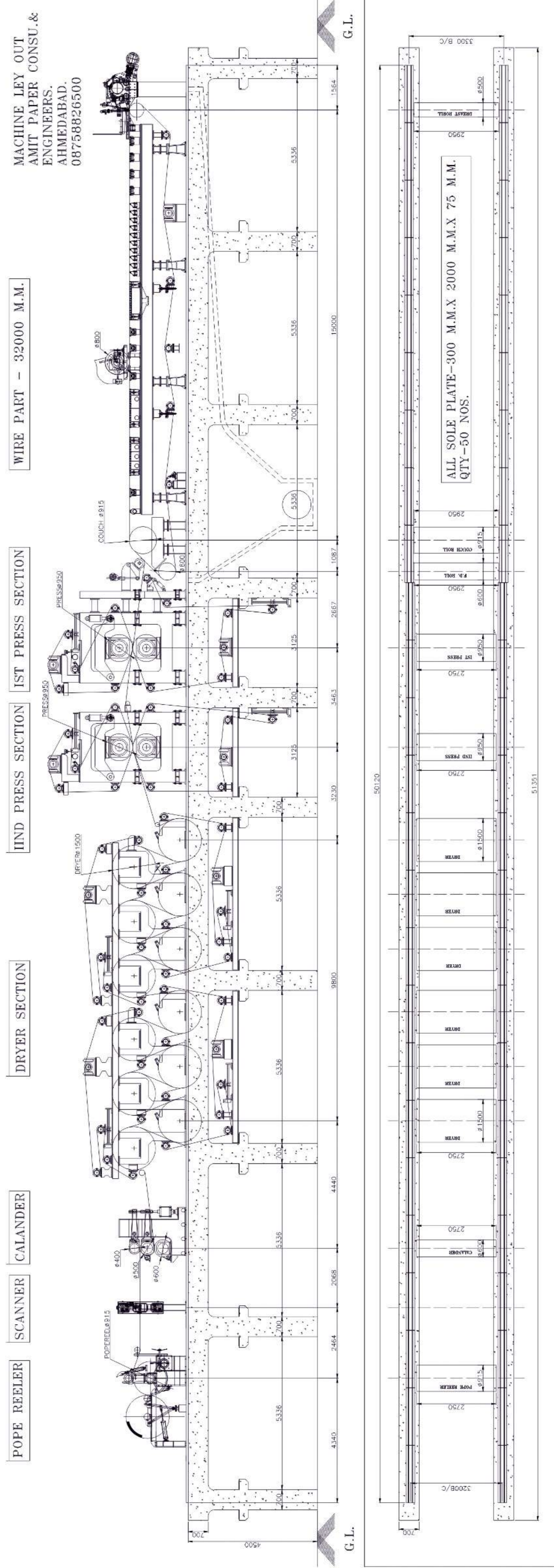

BUILDING ELEVATION

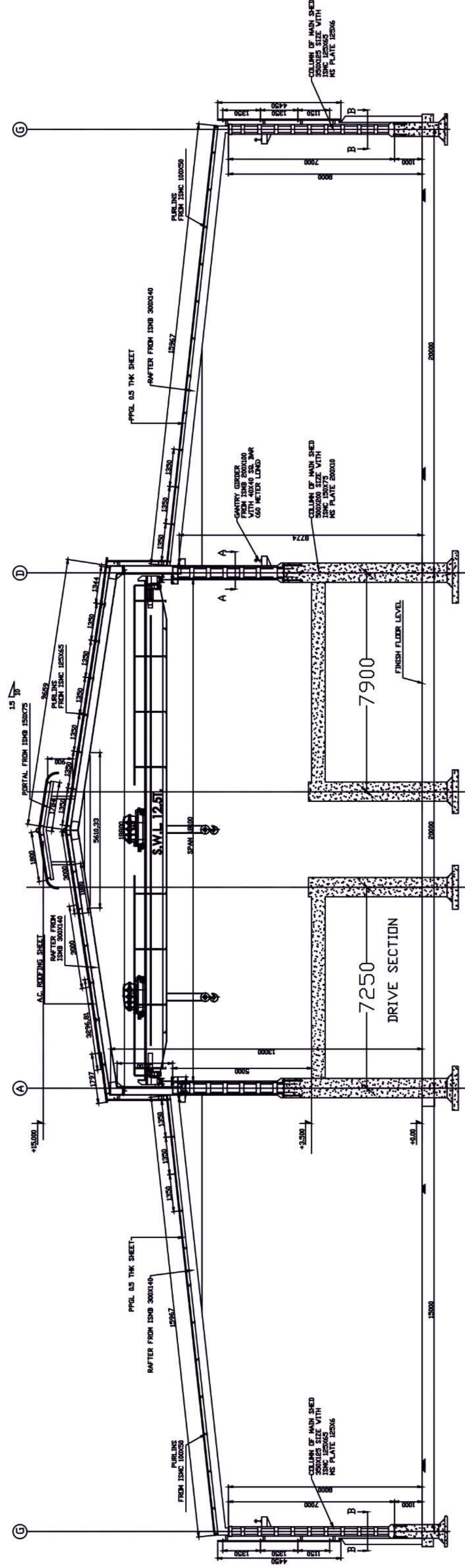

SECTION 4-4

SECTION AA

- 16.00 M LVL
MONITOR
LEVEL
- 15.00 M LVL
MAIN SHED
CENTRE
LEVEL
- 8.00 M LVL
LEAN ROOF
LEVEL
- 2.40 M LVL
BRICKWORK
LEVEL
- 0.00 M LVL
GROUND FLOOR
LEVEL

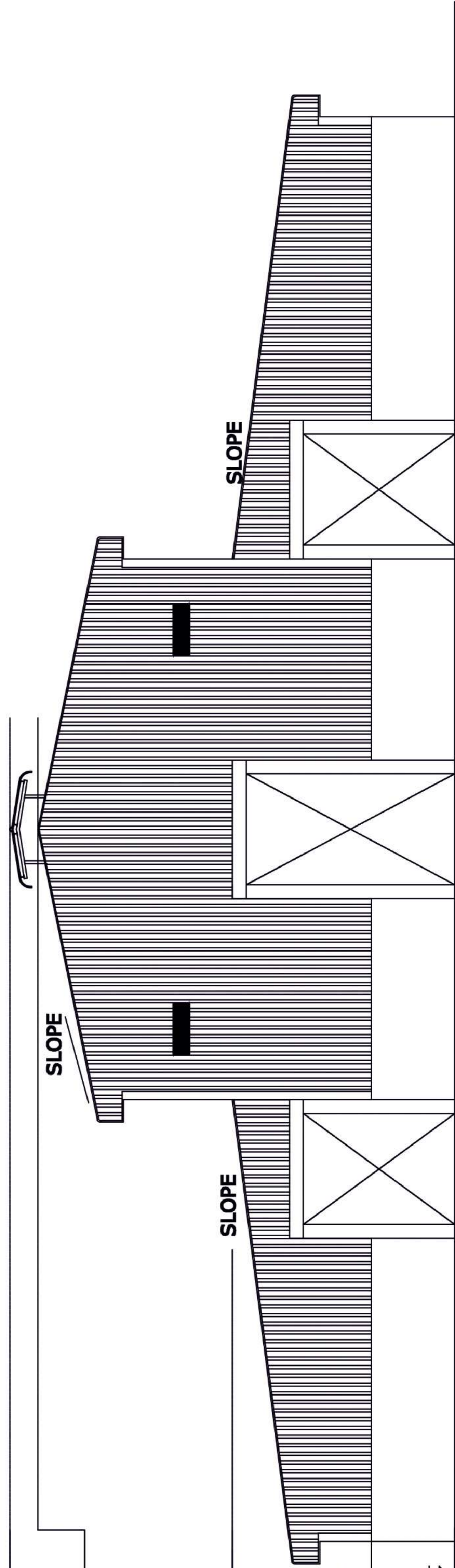

ELEVATION AA

EFFLUENT TREATMENT PLANT (ETP LAYOUT)

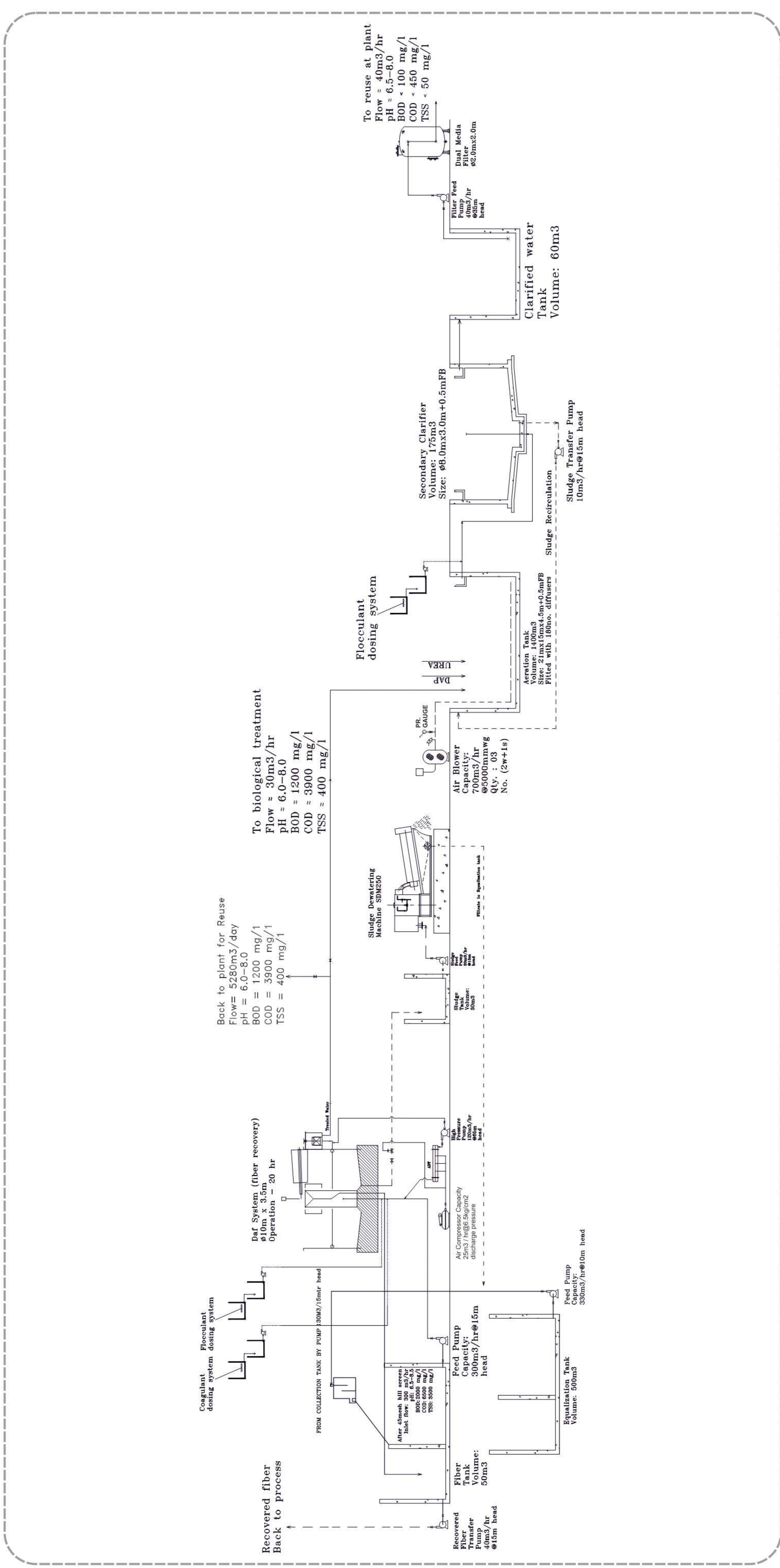

ETP PLANT LAYOUT

Bottom Layer

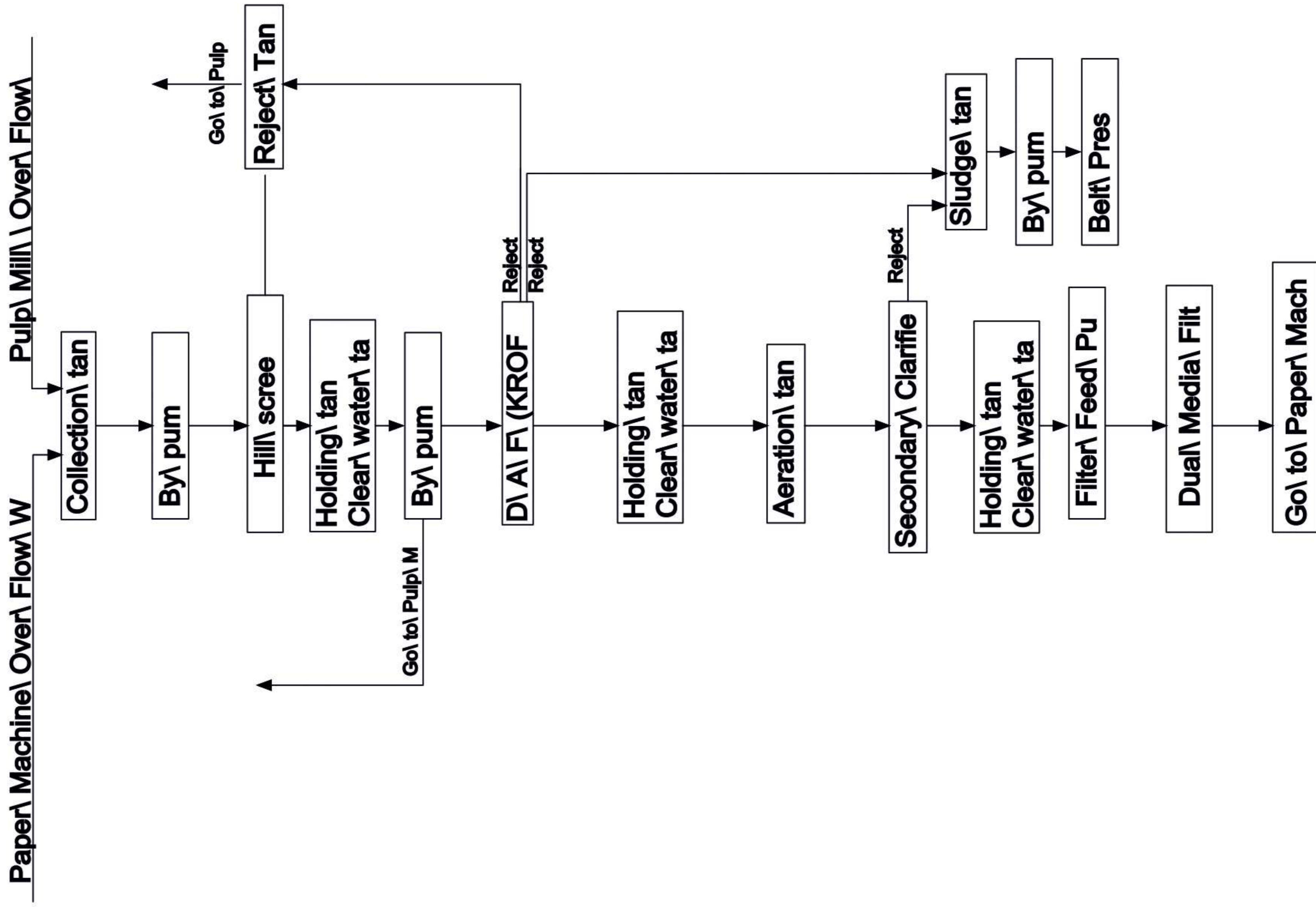

Top Layer

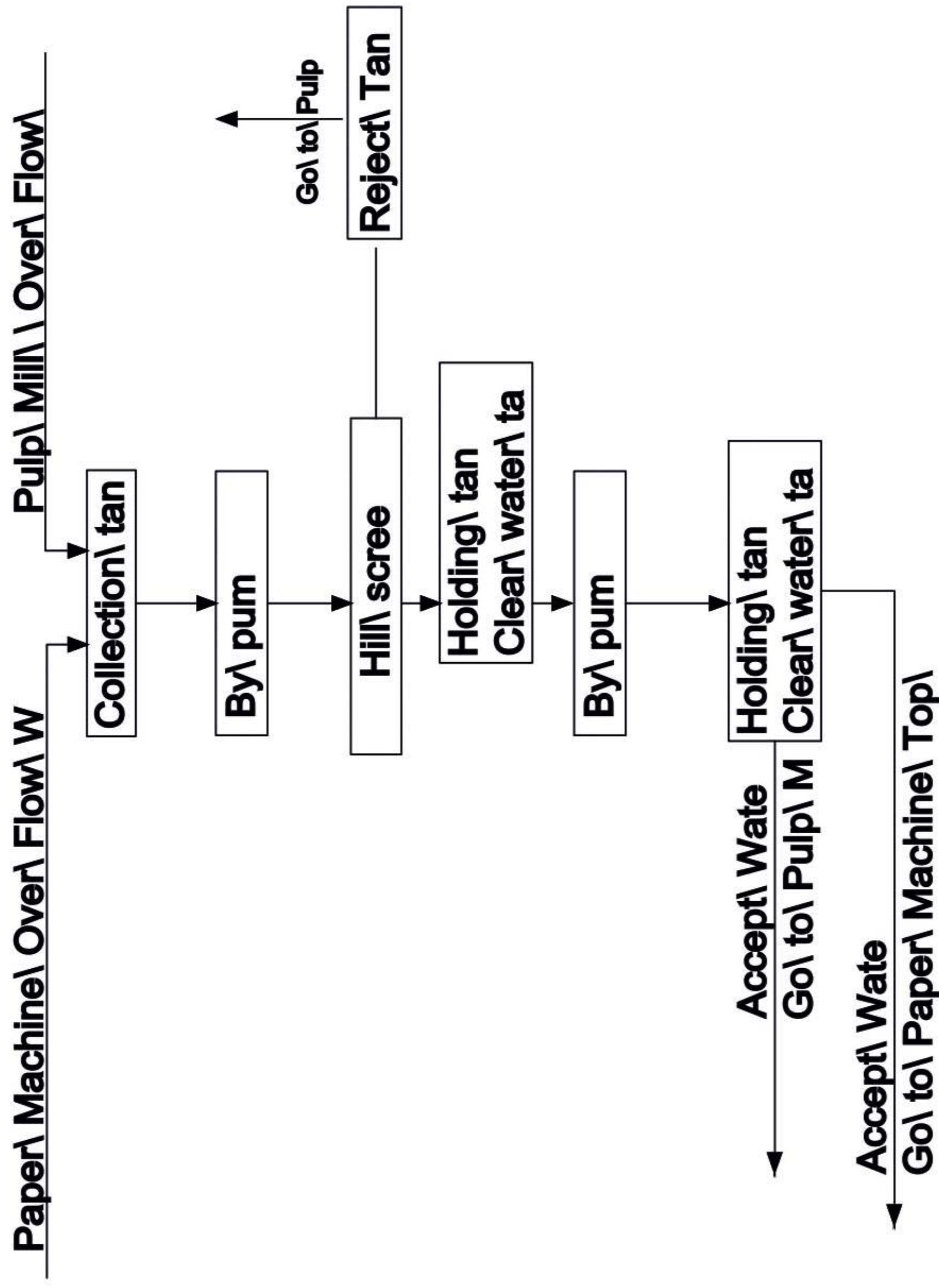

STEAM & CONDENSATE RECOVERY SYSTEM CASCADING SYSTEM

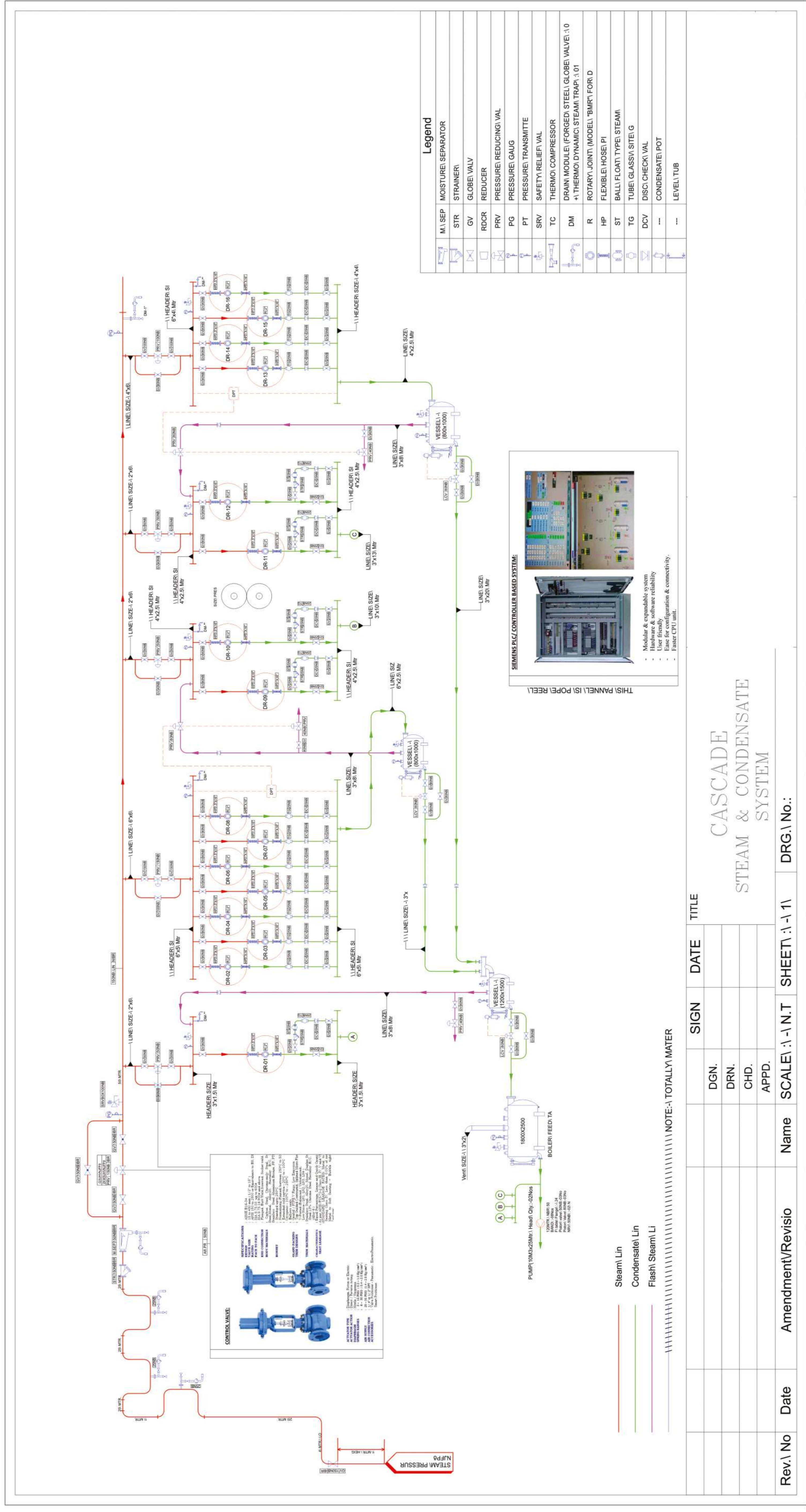

Rev. No	Date	Amendment/Revisio	Name	SCALE	SHEET	DRG. No.:
				1:1	1-1	

SIGN	DATE	TITLE
DGN.		CASCADE STEAM & CONDENSATE SYSTEM
DRN.		
CHD.		
APPD.		

M.I. SEP	MOISTURE SEPARATOR
STR	STRAINER
GV	GLOBE VALV
RED	REDUCER
PRV	PRESSURE REDUCING VAL
PG	PRESSURE GAUG
PT	PRESSURE TRANSMITTE
SRV	SAFETY RELIEF VAL
TC	THERMO COMPRESSOR
DM	DRAIN MODULE FORGED STEEL GLOBE VALVE 1.0 -1 THERMO DYNAMIC STEAM TRAP 1.01
R	ROTARY JOINT MODEL 'BMR' FOR D
HP	FLEXIBLE HOSE PI
ST	BALL FLOAT TYPE STEAM
TG	TUBE GLASSIN SITE G
DCV	DISC CHECK VAL
---	CONDENSATE POT
---	LEVEL TUB

SIEMENS PLC CONTROLLER BASED SYSTEM:

THIS IS PANNEL ISI POPEL REEL

- Modular & expandable system
- Hardware & software reliability
- User friendly
- Ease for configuration & connectivity
- Fastest CPU unit.

Steam Lin
 Condensate Lin
 Flash Steam Li

NOTE-1 TOTAL WATER

PRODUCTION PROCESS

PULPING SECTION

MACHINE SECTION

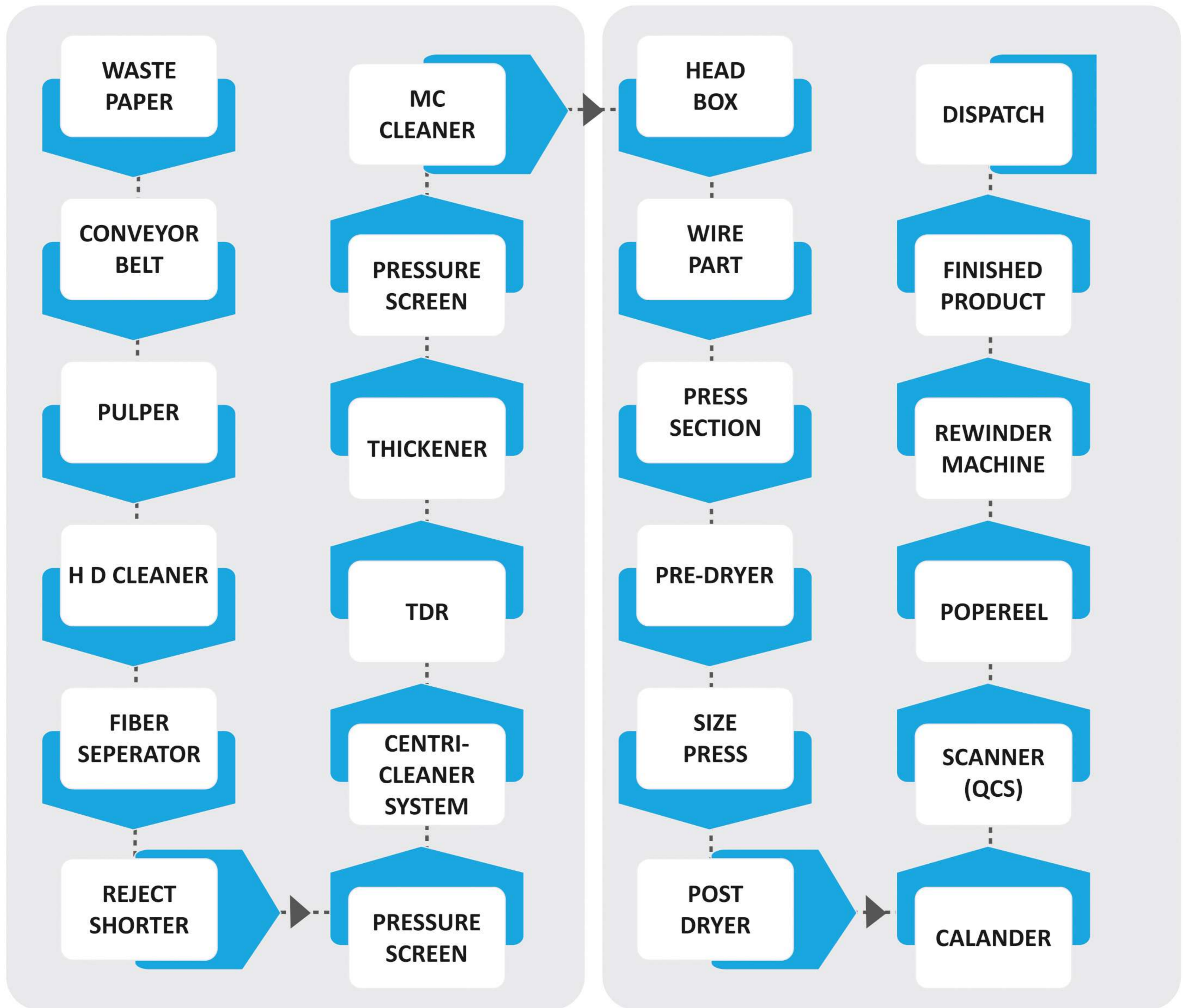

DOUBLE LAYER FLOW DIAGRAM

BOTTOM LAYER

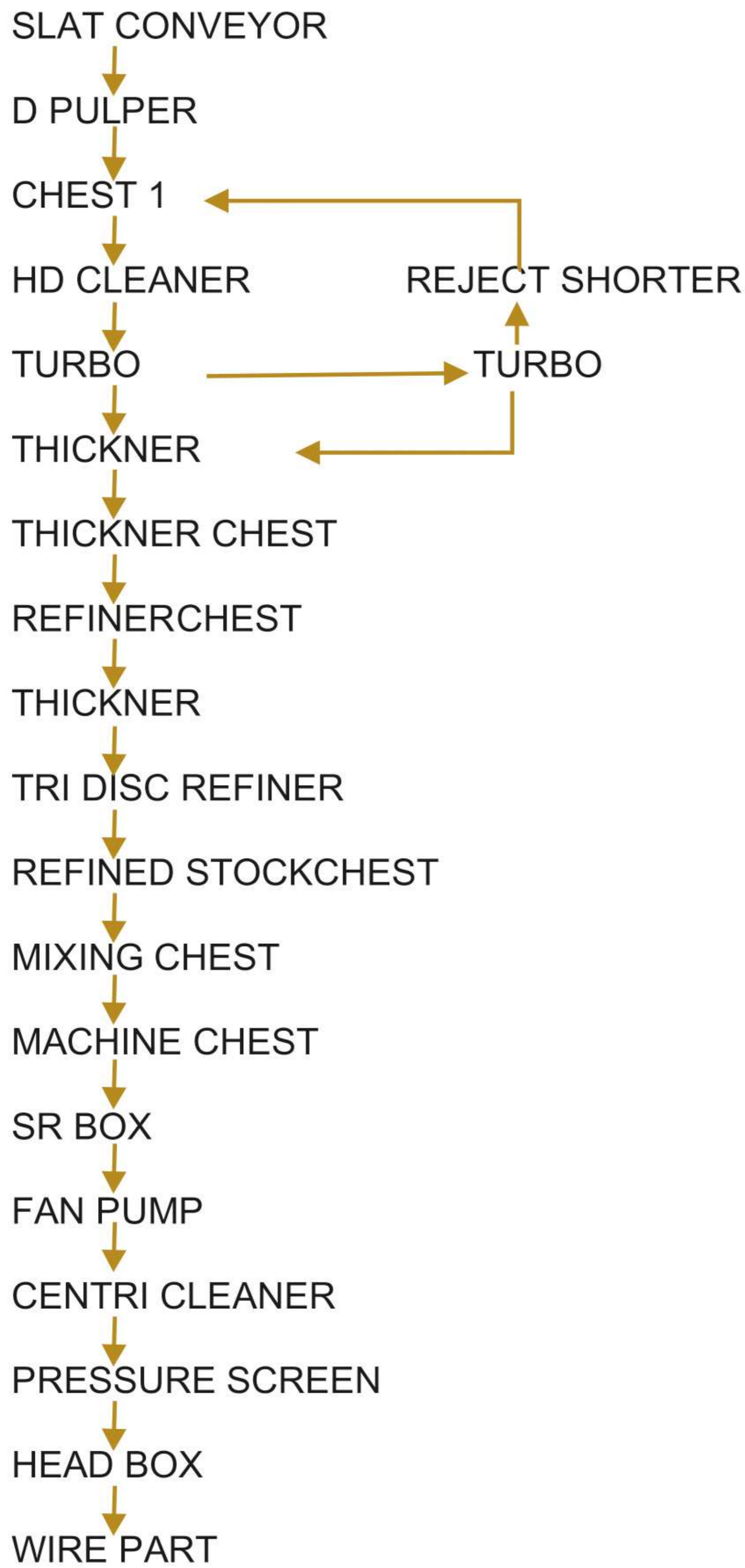

TOP LAYER

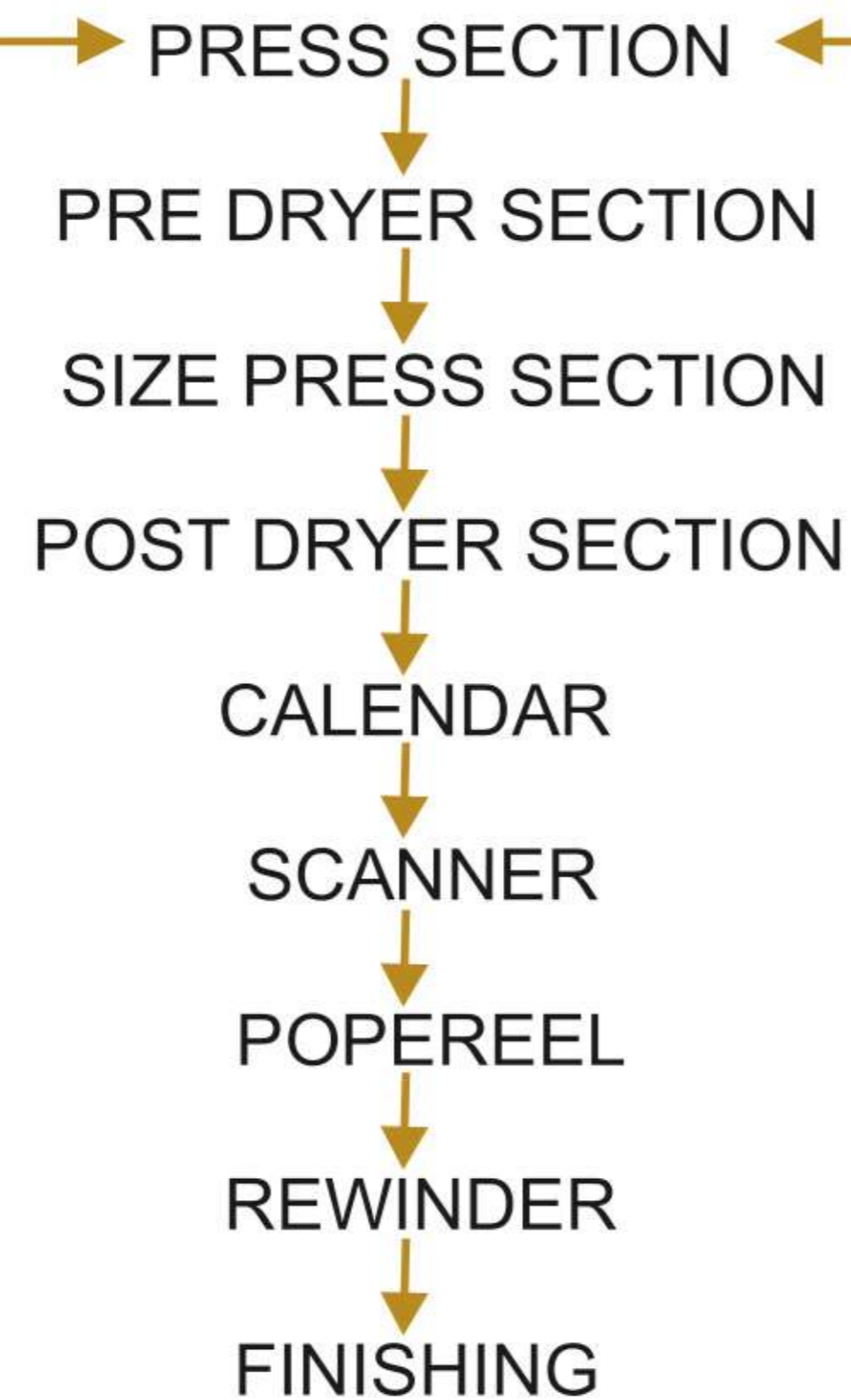
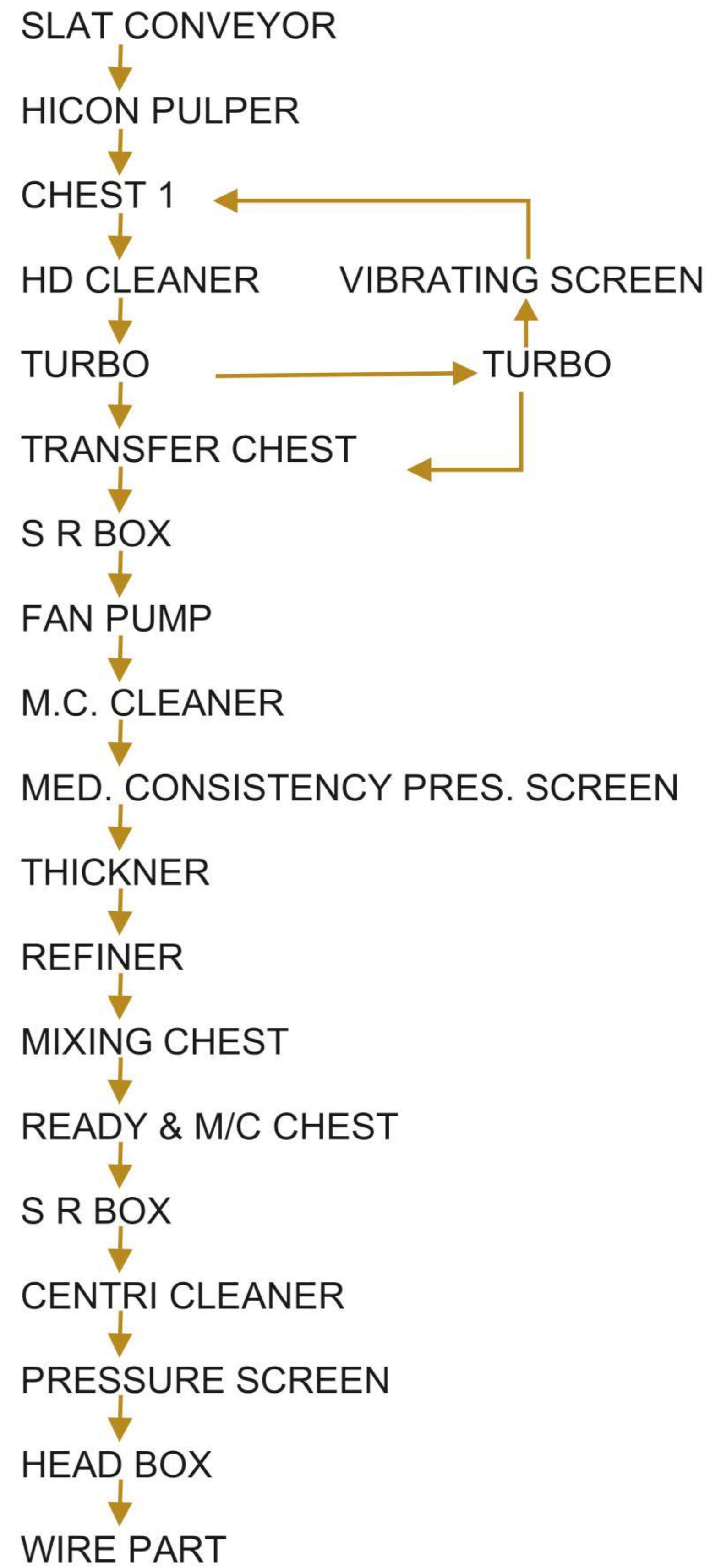

WE CAN SUPPLY THE FOLLOWING EQUIPMENTS

Paper making Machine Range from 10 to 400 TPD TURNKEY PROJECTS :

- Fourdriner Paper Machine
- Cylinder Mould Paper
- Tissue Paper
- Crescent Former Tissue
- Suction Former Tissue
- Kraft Paper Machine
- Corrugated Paper Machine
- A4 Copy Paper Machine
- Writing/Printing Machine
- Offset Paper Machine
- Newsprint Paper Machine

RANGE OF STOCK PREPARATION :

- Conveyor (Belt, Slat)
- Pulper (ATS Type, Hydro, D Type, High and Low Consistency Pulper, Dilution)
- Decker Thickener, PDF and Folding Thickener, B2 type Thickener
- Centricleaner
- Chest Agitator
- Turbo Separator
- Coarse Screen
- Pressure Screen
- Vibrating Screen
- Pressure Screen (Medium, Low, Washing Cycle)
- High Density Cleaner
- Hot Dispensor System
- Deinking Unit
- Tri Disc Refiner
- Poly Disc Filter
- Fractionator
- Horizontal Reject Shorter, Fiber Shorter
- Detrasher
- Grapple
- Trommel Screen
- Ragger
- Trashwell
- Fiber Saver
- Junk Trap
- Rope Cutter
- Stock Regulation Box

RANGE OF PAPER MACHINE :

- Bottom Wire Assembly
(Headbox – Pressurized, Opentype, Hydraulic)
- Top Wire Assembly
(Headbox – Pressurized, Open type, Hydraulic)
- Wire Part
- Press Section (Plain, Blind Drill)
- M G Cylinder
- Dryer Section
- Size Press with Kitchen
- Calander
- Popereel with Tambour Roll
- Slitter Rewinder
- Sheet Cutter
- Complete Drive Arrangement (individual and Silent Drive)
- Sole Plate
- Couch Pit Agitator
- Former - R.F, VAT
- Rope Carrier System

OTHER AUXILIARY EQUIPMENTS

- All Stock and ETP Pump
- Vaccum System with Separator
- Air Compressor
- EOT Crane
- Laboratory
- Workshop
- Weight Bridge Scale Unit
- ETP (Fiber Recovery Unit)
- Boiler (FBC, COAL BASED, DIESEL FIRE, ETC)
- Fire Hydrant
- Forkclip and Tractor (MATERIAL HANDLING)
- Steam condensate system
- Electrification
- C Oil Hydraulic System
- Platform and Ladder
- Machine Clothing (Felt and Wires, SLDF Screen)
- All Pipeline, Valve, Panel, Cable with Drive
- Scanner
- Core Pipe Making Machine
- Reel Stretch Rapping Machine
- Consistency Regulator
- Basic Weight Valve
- Hardware Material

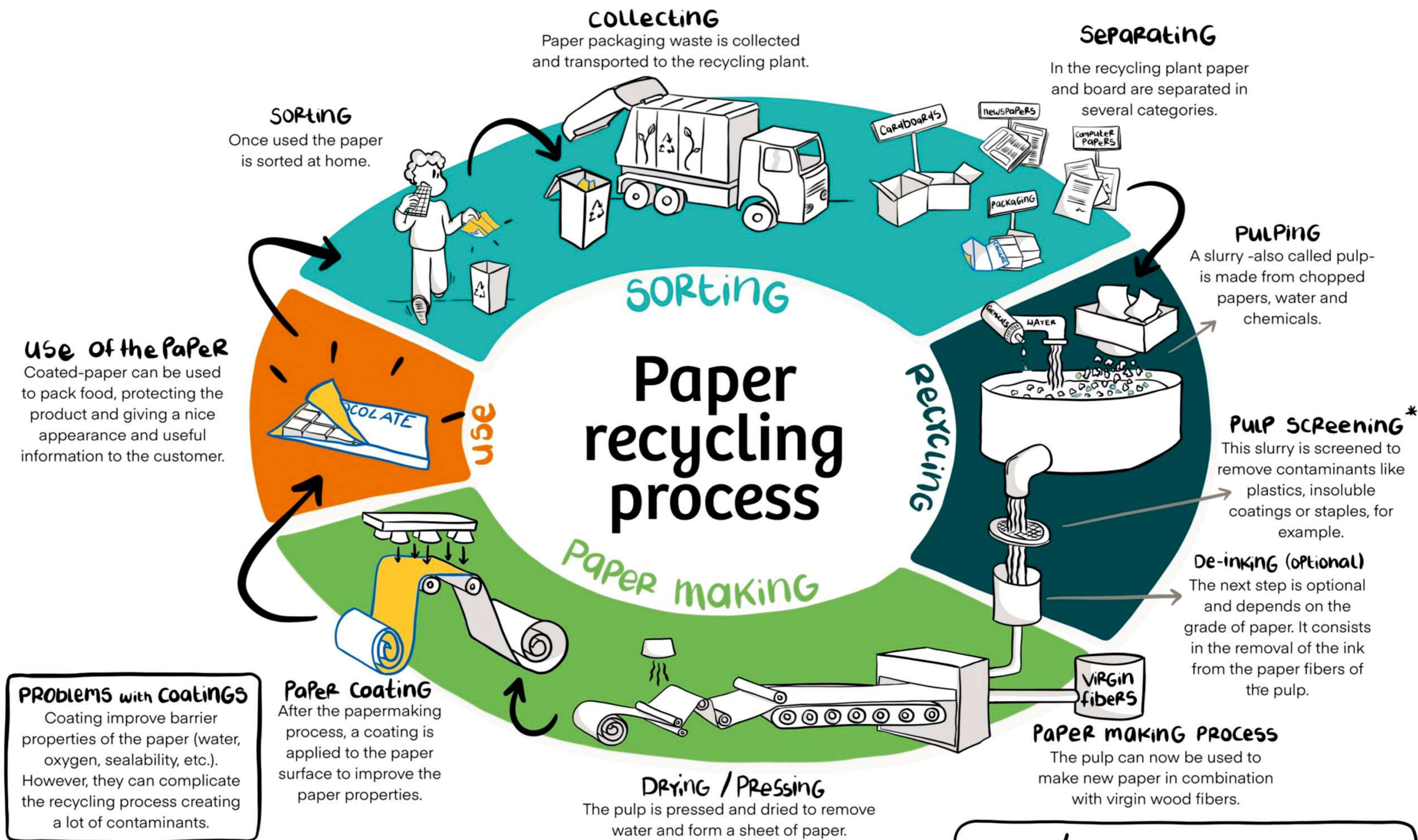

GROUP OF COMPANIES

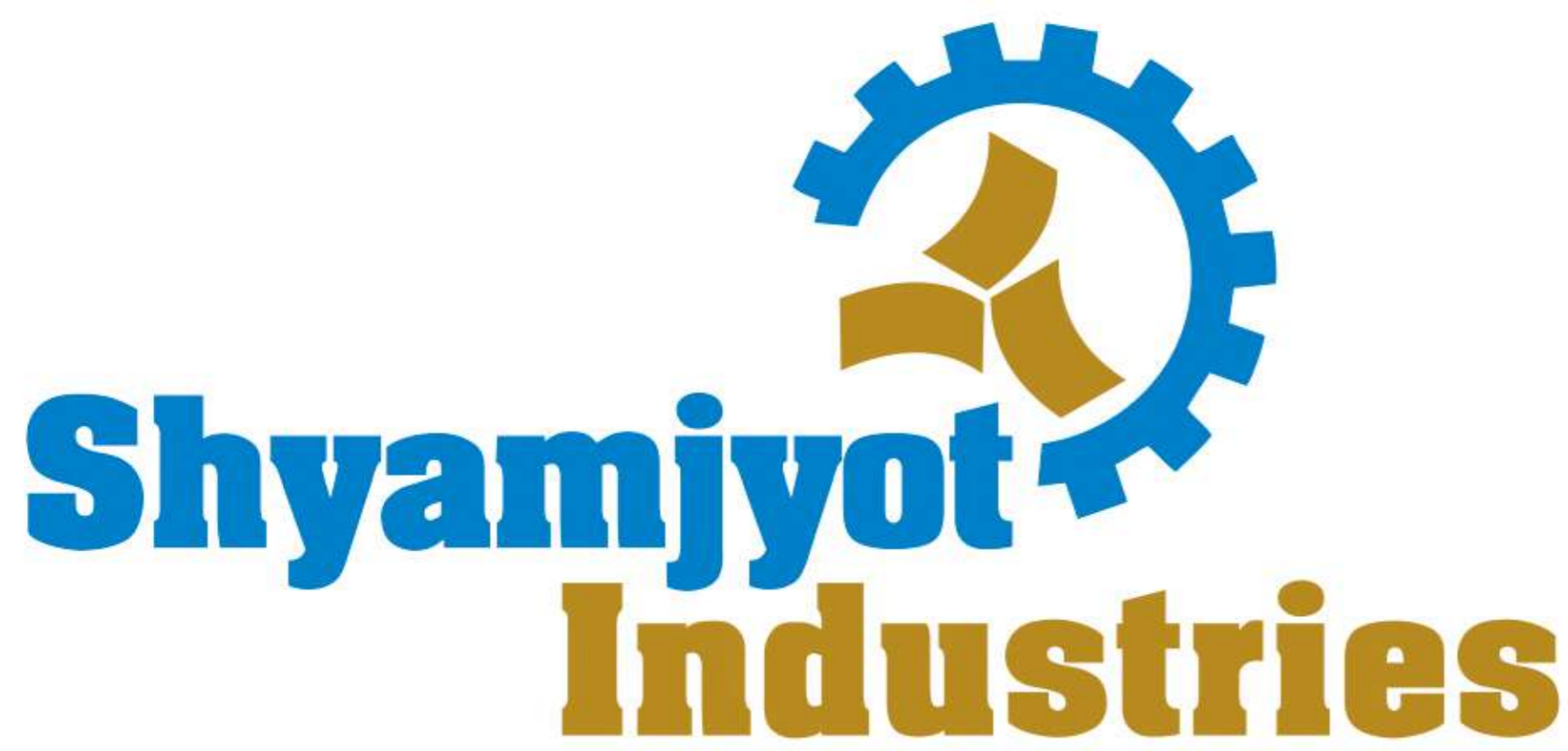

WORKSHOP :

📍 Shed No. 150, Raghuveer Estate-3, Nr. Vatva Railway Station, SLM Mill Compound, Vatva, Ahmedabad, Gujarat-382445.

☎ +91 9825256016

✉ Email : infoshyamjyotindustries@gmail.com

🌐 web : www.shyamjyotindustries.com

www.shyamjyotindustries.com